

# STRC & MPAC series

Flow rate up to 1000 l/min



## Description

## Technical data

### Suction filters

**Flow rate up to 1000 l/min**

#### STRC

STRC is a range of suction strainers for protection of the downstream pump against the coarse contamination.

They are placed below the oil level directly connected to the suction line of the pump.

#### Available features:

- Female threaded connections up to 3", for a maximum flow rate of 1000 l/min
- Bypass valve, to relieve excessive pressure drop across the filter media

#### Common application:

- Mobile machines (Construction and Agriculture machines)
- Industrial equipment

#### MPAC

MPAC is a range of suction strainers for protection of the downstream pump against the coarse contamination.

They are placed below the minimum oil level, directly connected to the suction line of the pump.

The robust design allows the use of these filters in any heavy duty application.

#### Available features:

- Female threaded connections up to 3", for a maximum flow rate of 1000 l/min
- Magnetic filter (MPAC), to hold the ferrous particles

#### Common application:

Industrial equipment

#### STRC materials

- 1 - Connection: Polyamide, GF reinforced
- 2 - Core tube: Tinned steel
- 3 - Wire mesh
- 4 - End cap: Polyamide, GF reinforced
- 5 - Bypass valve: Polyamide, GF reinforced - Steel

#### MPAC materials

- 1 - Connection: Aluminium
- 2 - Magnetic filter
- 3 - Tie rod: Galvanized steel
- 4 - End cap: Galvanized steel
- 5 - Core tube: Galvanized steel
- 6 - Filter media: Wire mesh
- 7 - Bottom: Galvanized steel
- 8 - Washer: Galvanized steel
- 9 - Self-locking nut: Galvanized steel - Polyamide

#### Bypass valve

Opening pressure 30 kPa (0.3 bar)

#### Elements

Fluid flow through the filter element from OUT to IN.

#### Temperature

From -25 °C to +110 °C

## Quantity

Series and size	pcs/pack
<b>STRC</b> 045 - 050	12
<b>STRC</b> 065 - 070 - 086 - 100	6
<b>STRC</b> 140 - 150	1
<b>MPAC</b> 050	12
<b>MPAC</b> 070 - 100	6
<b>MPAC</b> 140	1

## Weights [kg]

Filter series	
<b>STRC</b>	see page 37
<b>MPAC</b>	see page 39

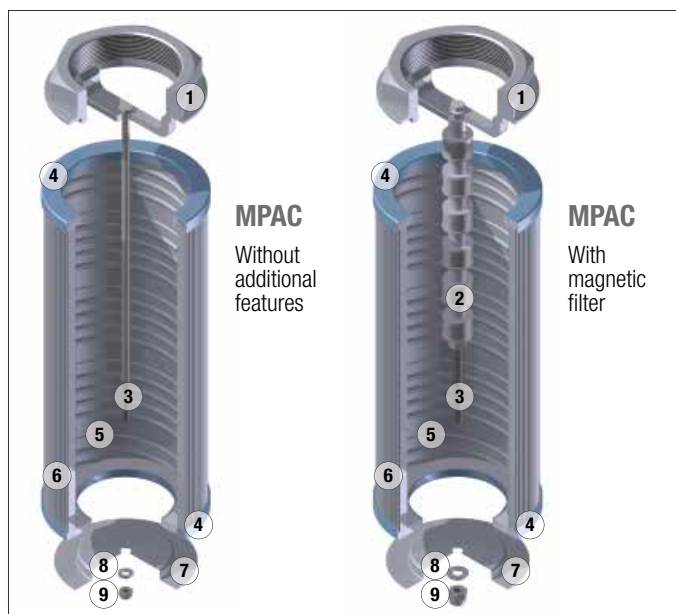
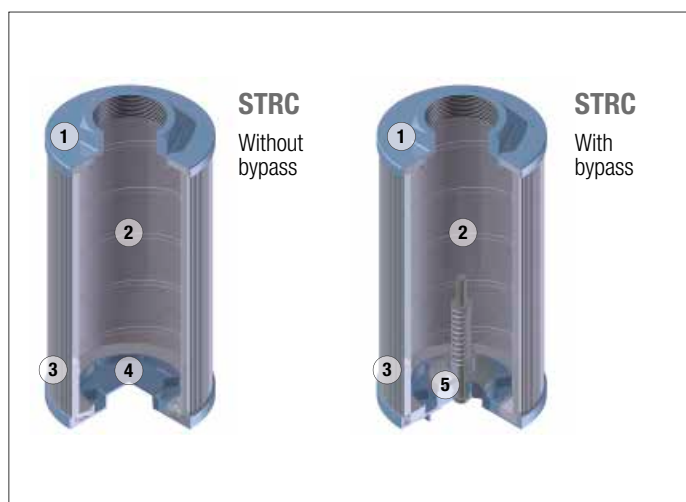

Flow rates [l/min]

Filter series	Thread	l/min
<b>STRC &amp; MPAC</b>	3/8"	19
	1/2"	28
	3/4"	67
	1"	126
	1 1/4"	167
	1 1/2"	258
	2"	480
	2 1/2"	854
	3"	995

**Maximum flow rate for a complete suction filter with a pressure drop  $\Delta p = 0.08$  bar.**

The reference fluid has a kinematic viscosity of 30 mm<sup>2</sup>/s (cSt) and a density of 0.86 kg/dm<sup>3</sup>.

For different pressure drop or fluid viscosity we recommend to use our selection software available on [www.mpfiltri.com](http://www.mpfiltri.com).

You can also calculate the right size using the formulas present on the FILTER SIZING paragraph at the beginning of the full catalogue or at the beginning of the filter family brochure.

Please, contact our Sales Department for further additional information.

Filter series	00 - without bypass	03 - with bypass
<b>STRC</b>	•	•
<b>MPAC</b>	•	-

Hydraulic symbols

**Pressure drop**

Filters pressure drop  $\Delta p$  in function of connection type

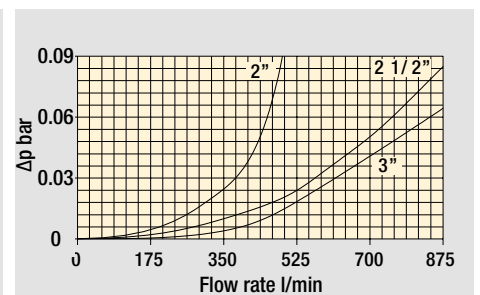
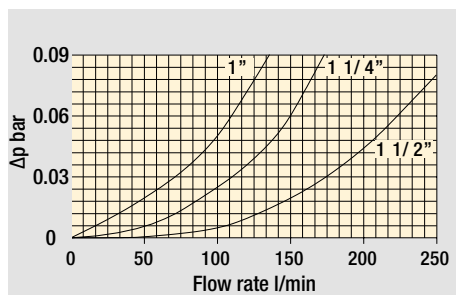
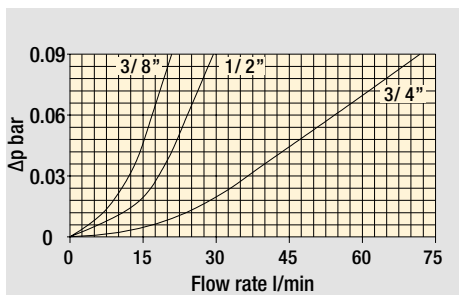

The curves are plotted using mineral oil with density of 0.86 kg/dm<sup>3</sup> in compliance with ISO 3968.  $\Delta p$  varies proportionally with density.

Maximum total pressure drop ( $\Delta p$  max) allowed by a new and clean filter

Filter family	$\Delta p$ max	
Suction	0.08 bar	1.15 psi

### COMPLETE FILTER

<b>Series</b>	Example 1:	STRC	045	10	M0060	A	N	03	FG038	0	ON	NN	P01	NN
<b>STRC</b>	Example 2:	STRC	100	20	M0250	A	N	00	FN200	0	ON	NN	P01	NN

<b>Size</b>	
045	086
050	100
065	140
070	150

<b>Length</b>	Size:	045	050	065	070	086	100	140	150
10		•	•	•	•	•	•	•	•
20		-	-	•	•	•	•	•	•
30		-	-	-	-	•	-	•	•
40		-	-	-	-	-	-	•	-

<b>Filtration rating (filter media)</b>	
M0025	Wire mesh 25 µm
M0060	Wire mesh 60 µm
M0090	Wire mesh 90 µm
M0250	Wire mesh 250 µm

<b>Element Δp</b>	
A	1 bar

<b>Seals and treatments</b>	
N	Without seals

<b>Bypass</b>	
00	Without bypass
03	With bypass 30 kPa (0.3 bar)

<b>Connection type</b>	
FG	Thread ISO 1179-2 (GAS)
FN	Thread ANSI/ASME B 1.20.1 (NPT)

<b>Nominal thread</b>																			
	Size:	045	050	065	070	086	100	140	150										
	Length	10	10	10	20	10	20	10	20	30	10	20	10	20	30	40	10	20	30
038	3/8"	•	•	-	-	-	-	-	-	-	-	-	-	-	-	-	-	-	-
012	1/2"	•	•	•	-	•	•	-	-	-	-	-	-	-	-	-	-	-	-
034	3/4"	-	-	•	•	•	•	-	-	-	-	-	-	-	-	-	-	-	-
100	1"	-	-	-	•	-	•	-	-	-	-	-	-	-	-	-	-	-	-
114	1 1/4"	-	-	-	-	-	-	-	-	•	•	-	-	-	-	-	-	-	-
112	1 1/2"	-	-	-	-	-	-	•	•	•	•	•	-	-	-	-	-	-	-
200	2"	-	-	-	-	-	-	•	•	•	-	•	•	•	-	-	•	-	-
212	2 1/2"	-	-	-	-	-	-	-	-	-	-	-	-	-	•	-	-	•	-
300	3"	-	-	-	-	-	-	-	-	-	-	-	-	-	•	•	-	•	•

<b>Additional connections</b>	
0	Without additional connections

<b>Connections for clogging indicators</b>	
ON	Without connection

<b>Additional features</b>	
NN	Without additional features

<b>Version</b>	
P01	Standard catalogue item

<b>Certificates</b>	
NN	Without certificates

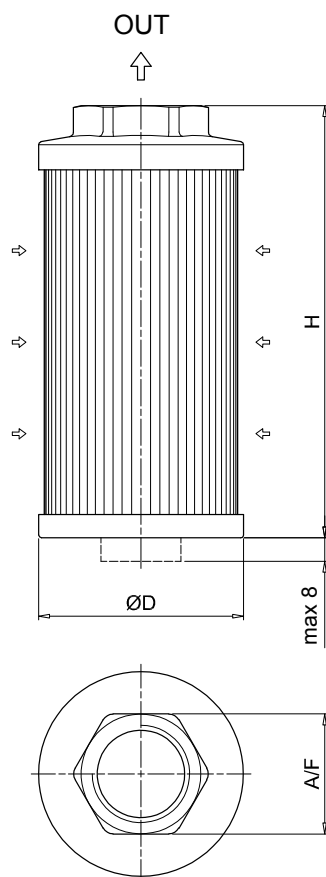

STRC							
Size	ØD [mm]	Length	Nominal thread		H [mm]	A / F [mm]	Weight [kg]
<b>045</b>	46	10	3/8"	1/2"	105	30	0.19
<b>050</b>	52	10	3/8"	1/2"	79		0.11
<b>065</b>	65	10	1/2"	3/4"	110	41	0.22
		20	3/4"	1"	144		0.24
<b>070</b>	70	10	1/2"	3/4"	95		0.18
		20	1/2"	3/4"	1"		141
<b>086</b>	86	10	1 1/2"	2"	143	69	0.33
		20	1 1/2"	2"	201		0.43
		30	1 1/2"	2"	261		0.53
<b>100</b>	99	10	1 1/4"	1 1/2"	137		0.47
		20	1 1/4"	1 1/2"	2"		227
<b>140</b>	130	10	1 1/2"	2"	160		101
		20	2"		262	0.94	
		30	2 1/2"	3"	272	1.10	
		40	3"		330	1.17	
<b>150</b>	150	10	2"		150	70	0.34
		20	2 1/2"		212	90	0.37
		30	3"		272	100	0.40

## Designation & Ordering code

### COMPLETE FILTER

<b>Series</b>	Example 1:	MPAC	070	10	M0060	A	N	00	FG034	0	ON	NN	P01	NN
<b>MPAC</b>	Example 2:	MPAC	140	30	M0250	A	N	00	FN300	0	ON	MA	P01	NN

**Size**

050
070
100
140

**Length**

Size:	050	070	100	140
10	•	•	•	•
20	-	•	•	•
30	-	-	-	•

**Filtration rating (filter media)**

<b>M0025</b> Wire mesh 25 µm	<b>M0090</b> Wire mesh 90 µm
<b>M0060</b> Wire mesh 60 µm	<b>M0250</b> Wire mesh 250 µm

**Element Δp**

<b>A</b> 1 bar
----------------

**Seals and treatments**

<b>N</b> Without seals
------------------------

**Bypass**

<b>00</b> Without bypass
--------------------------

**Connection type**

<b>FG</b> Thread ISO 1179-2 (GAS)
<b>FN</b> Thread ANSI/ASME B 1.20.1 (NPT)

**Nominal thread**

Length	Size:	050		070		100		140	
		10	10	20	10	20	10	20	30
<b>038</b> 3/8"		•	-	-	-	-	-	-	-
<b>012</b> 1/2"		•	•	-	-	-	-	-	-
<b>034</b> 3/4"		-	•	•	-	-	-	-	-
<b>100</b> 1"		-	-	•	•	-	-	-	-
<b>114</b> 1 1/4"		-	-	-	•	•	-	-	-
<b>112</b> 1 1/2"		-	-	-	-	•	•	-	-
<b>200</b> 2"		-	-	-	-	-	•	•	•
<b>212</b> 2 1/2"		-	-	-	-	-	-	•	-
<b>300</b> 3"		-	-	-	-	-	-	-	•

**Additional connections**

<b>0</b> Without additional connections
---

**Connections for clogging indicators**

<b>ON</b> Without connection
------------------------------

**Additional features**

<b>NN</b> Without additional features
<b>MA</b> With magnetic filter

**Version**

<b>P01</b> Standard catalogue item
------------------------------------

**Certificates**

<b>NN</b> Without certificates
--------------------------------

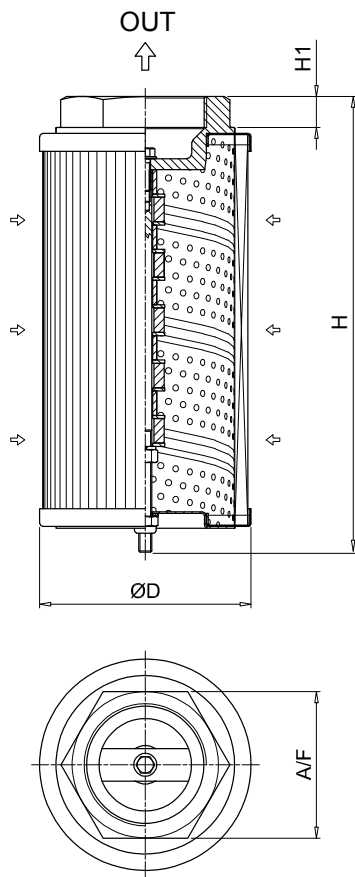

MPAC									
Size	ØD [mm]	Length	Nominal thread	H [mm]	H1 [mm]	A/F [mm]	Weight [kg]		
<b>050</b>	50	10	3/8"	98	16	28	0.17		
			1/2"	113			0.27		
<b>070</b>	70	10	3/4"	115	18	42	0.36		
		20	160	0.39					
		1"	145	0.35					
<b>100</b>	99	10	1 1/4"	148	20	60	0.54		
		20	239	0.63					
		1 1/2"	174	0.91					
<b>140</b>	136	10	2"	162	13	80	0.98		
		20	272	1.00					
		30	2 1/2"	281			20	90	1.60
			2"	322			13	80	1.60
		3"	335	22			106	1.93	

Suitable indicator types

**V ACUUM INDICATORS**

Vacuum indicators are used on the Suction line to check the efficiency of the filter element.

They measure the pressure downstream of the filter element.

Standard items are produced with R 1/4" EN 10226 connection.

Available products with R 1/8" EN 10226 to be fitted on MPS series.

Vacuum indicators are identified in the Hydraulic Filtration catalogue and in the Quick Reference Guide table by the letter "V".

Example:

**V** VVB20P01

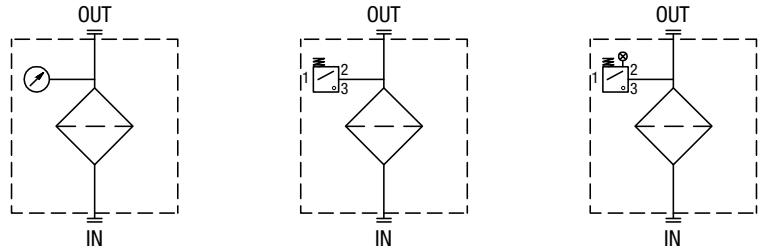

**B BAROMETRIC (PRESSURE) INDICATORS**

Pressure indicators are used on the Return line to check the efficiency of the filter element.

They measure the pressure upstream of the filter element.

Standard items are produced with R 1/8" EN 10226 connection.

Barometric (pressure) indicators are identified in the Hydraulic Filtration catalogue and in the Quick Reference Guide table by the letter "B".

Example:

**B** BVA14P01

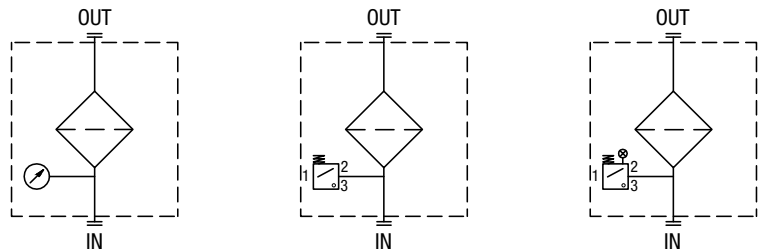

**D DIFFERENTIAL PRESSURE INDICATORS**

Differential pressure indicators are used on the Pressure line to check the efficiency of the filter element.

They measure the pressure upstream and downstream of the filter element (differential pressure).

Standard items are produced with special connection G 1/2" size.

Also available in Stainless Steel models. Differential pressure indicators are identified in the Hydraulic Filtration catalogue and in the Quick Reference Guide table by the letter "D".

Example:

**D** DVA20xP01

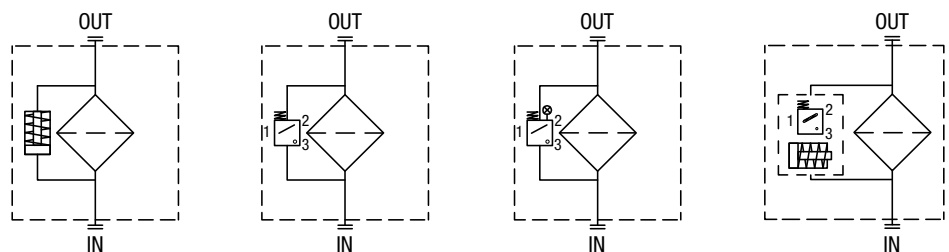



## Designation & Ordering code

### VACUUM INDICATORS

Series	Configuration example 1:	VE	A	21	V	A	50	P01	EX
<b>VE</b> Electrical vacuum indicator	Configuration example 2:	VL	B	21	A	A	71	P01	
<b>VL</b> Electrical/Visual vacuum indicator	Configuration example 3:	VV	R	20				P01	
<b>VV</b> Vacuum gauge									

Type VE - VL	Type VV	SF2	SFEX
<b>A</b> Connection EN 10226 - R1/4"	<b>A</b> Axial connection EN 10226 - R1/4"	•	-
<b>B</b> Connection EN 10226 - R1/8"	<b>B</b> Axial connection EN 10226 - R1/8"	-	•
	<b>R</b> Radial connection EN 10226 - R1/4"	•	-
	<b>S</b> Radial connection EN 10226 - R1/8"	-	•

Vacuum setting	VE	VL	VV
<b>20</b> -0.16 bar	-	-	•
<b>21</b> -0.21 bar	•	•	-

Seals	VEA - VLA	VEB - VLB
<b>A</b> NBR	•	•
<b>V</b> FPM	•	-

Thermostat	VE	VL
<b>A</b> Without	•	•

Electrical connections	VE	VL
<b>50</b> Connection EN 175301-803	•	-
<b>51</b> Connection EN 175301-803, transparent base with lamps 24 Vdc	-	•
<b>52</b> Connection EN 175301-803, transparent base with lamps 110 Vdc	-	•
<b>53</b> Connection EN 175301-803, transparent base with lamps 230 Vac	-	•
<b>71</b> Connection IEC 61076-2-101 D (M12), black base with lamps 24 Vdc	-	•

Option	P01	Pxx
<b>P01</b> MP Filtri standard		
<b>Pxx</b> Customized		

Certifications	VEA21A	VEA21V	VEB	VL	VV
Without	•	•	•	•	•
<b>EX</b> ATEX certification	•	•	•	-	-
<b>UL</b> UL certification	•	-	-	-	-